

FD/HD 140

230 V / 50 Hz

SELF-CONTAINED ICE CUBE MACHINE

FEATURES CARACTERÍSTICAS

- ▶ **PRODUCE FULL DICE ICE CUBES OR HALF DICE ICE CUBES**
PRODUCE CUBITOS DE DADO Y MEDIO DADO
- ▶ **STIF: STRONG INOX FRAME. SOLID MACHINE STRUCTURE IN 4 COLUMNS WITH AISI 304 STAINLESS STEEL FRAME**
STIF: STRONG INOX FRAME. MÁQUINA CON SÓLIDA ESTRUCTURA DE 4 COLUMNAS Y CARROCEÍA EN ACERO INOXIDABLE AISI 304.
- ▶ **STRONGEST DOOR IN THE MARKET. MADE OF STAINLESS STEEL. OPENING AND DAMPING SYSTEM PATENTED BY ITV.**
PUERTA MÁS SÓLIDA EN EL MERCADO. HECHA DE ACERO INOXIDABLE. SISTEMA DE APERTURA Y AMORTIGUACIÓN PATENTADO POR ITV.
- ▶ **FRONT VENTILATION CONCEPT: FRONTAL IN-OUT AIR SYSTEM ALLOWS 'BUILT IN' MACHINES**
CONCEPTO FRONT VENTILATION: VENTILACIÓN FRONTAL IN-OUT QUE PERMITE LA INSTALACIÓN ENCASTRADA DE LA MÁQUINA
- ▶ **CLEANING SWITCH: ALLOWS CIRCULATION OF WATER WITH DESCALING PRODUCT (CALKLIN OR SIMILAR) WITHOUT COOLING.**
BOTÓN DE LIMPIEZA: PERMITE RECIRCULAR EL AGUA CON EL DESINCRUSTANTE (CALKLIN O SIMILAR) SIN REFRIGERACIÓN
- ▶ **"NEVER STOP" MOTOR PUMP DEVELOPED BY ITV. PUMP WITHOUT SEALS, WHICH AVOIDS DETERIORATION IN HARD WATER**
BOMBA "NEVER STOP" DESARROLLADA POR ITV. BOMBA SIN RETENES QUE EVITA SU DETERIORO EN AGUAS DURAS
- ▶ **EASI: EASY ACCESS FOR SERVICE & INSTALLATION. ALL PANELS CAN BE DISASSEMBLED SEPARATELY.**
EASY ACCESS FOR SERVICE & INSTALLATION. FÁCIL ACCESO A CUALQUIER PUNTO YA QUE TODOS LOS PANELES PUEDEN SER DESMONTADOS DE FORMA INDEPENDIENTE.
- ▶ **ON/OFF LIGHTED ROCKER SWITCH IN FRONT PANEL**
INTERRUPTOR LUMINOSO DE FUNCIONAMIENTO ON/OFF EN EL PANEL FRONTAL
- ▶ **TROPICALIZED MACHINES (T CLASS) / HEIGHT ADJUSTABLE LEGS FROM 105MM TO 155MM**
MÁQUINAS TROPICALIZADAS (CLASE T) / PATAS DE ALTURA AJUSTABLE DE 105MM A 155MM



	24 H	10°C (Kg)	10°C (Kg)	21°C (Kg)	15°C (Kg)	(Kg)	(mm)	(mm)	
FD/HD 140 A		154	138	45	Width 762	Width 840	Average dimensions 23 mm (W) x 11 mm (D) x 26 mm (H) Dimensiones promedio		FD/HD 6'5cc
FD/HD 140 W		154	139		Depth 762	Depth 830			
					Height 838*	Height 970			

* WITH LEGS 943/993 CON PATAS 943/993

ACCESSORIES ACCESORIOS

INCLUDED



WATER INLET HOSE
MANGUERA DE ENTRADA DE AGUA



WATER OUTLET HOSE
MANGUERA DE DESAGÜE



4 HEIGHT ADJUSTABLE LEG KIT
KIT 4 PATAS ALTURA REGULABLE



WATER INLET FILTER GASKET
JUNTA DE FILTRO DE ENTRADA DE AGUA



MEDIUM SCOOP
PALA MEDIANA

NOT INCLUDED (OPTIONAL)



ANTI-LIMESCALE FILTER
FILTRO ANTICAL



PARTICLE FILTER
FILTRO ANTIPARTÍCULAS



ANTI-CHLORINE FILTER
FILTRO ANTICLORO



ANTI-LIMESCALE + ANTI-CHLORINE FILTER CS101
FILTRO ANTICAL + ANTICLORO CS101



C4 WATER SOFTENER
DESCALCIFICADOR C4



CALKLIN 50 CLEANER
PRODUCTO ANTICAL



4 WHEELS KIT
KIT 4 RUEDAS

RIGHT SIDE VIEW
VISTA LATERAL DERECHA

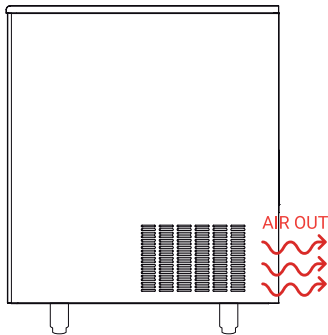

FRONTAL VIEW
VISTA FRONTAL

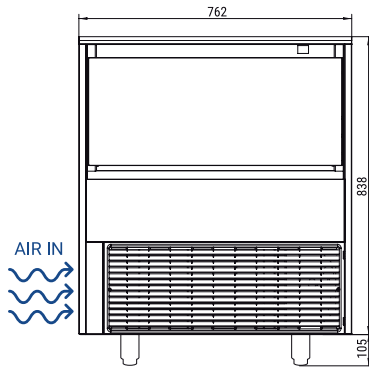

LEFT SIDE VIEW
VISTA LATERAL IZQUIERDA

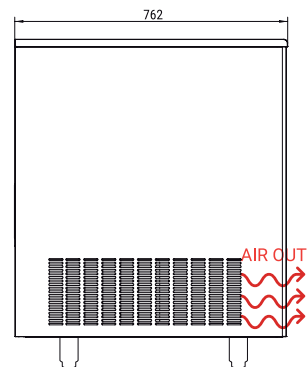

REAR VIEW
VISTA TRASERA

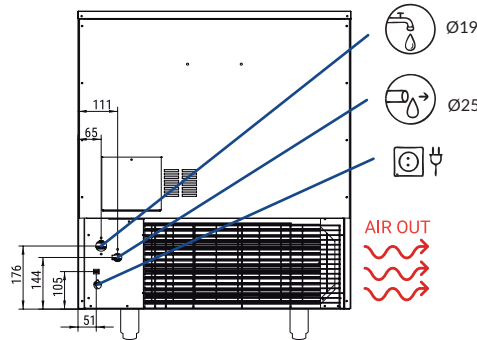

* All measurements in mm.
* Todas las cotas en mm.

OPERATING CONDITIONS CONDICIONES DE OPERACIÓN

PRODUCTION 50Hz PRODUCCIÓN 50 Hz

±10% V

5°C/43°C

5°C/35°C

1 bar/6 bar

144/288 Ice cubes/cycle

	V	Hz	ph
	230	50	1N

		FD/HD 140 AIR COOLED			
		10°	15°	21°	30°
		50°	60°	70°	86°
10°	154	145	136	129	
50°	146	138	130	123	
21°	130	120	111	105	
68°	120	108	100	91	
32°	120	108	100	91	
90°	120	108	100	91	
43°	120	108	100	91	
109°	120	108	100	91	

		FD/HD 140 WATER COOLED			
		10°	15°	21°	30°
		50°	60°	70°	86°
10°	154	245	136	129	
50°	146	139	130	129	
21°	130	120	117	117	
68°	120	113	110	100	
32°	120	113	110	100	
90°	120	113	110	100	
43°	120	113	110	100	
109°	120	113	110	100	

MODELS
MODELOS

FD/HD 140 A

FD/HD 140 W

	+c° -c°	ASHRAE CONDITIONS CONDICIONES ASHRAE	(W) 43°C	(n.) (mm²)	FUSE	100 Kg (Kwh)	(l/h) FULL HALF	HEAT REJECTED (W) (BTU/h)	(Kg)	(Kg)	(m³)
FD/HD 140 A		(W) (BTU/h)	(W) 43°C	(n.) (mm²)	FUSE	(Kwh)	(l/h) FULL HALF	(W) (BTU/h)	(Kg)	(Kg)	(m³)
FD/HD 140 A		551 1.882	710	2 1,5	10	16	17,5 17,5	- -	85	96	0,68
FD/HD 140 W		551 1.882	730	2 1,5	10	11,9	49,6 49,6	- -	85	96	0,68



EUROICE
P.I. La Reva, Av. Gremis, 1
46190 Ribarroja - Valencia - España
Phone: +34 96 166 76 36 | Fax: +34 961 668 944
www.euroice.it | info@euroice.it



SERVICE
SERVICIO ASISTENCIA TÉCNICA
service@euroice.it
+34 961 667 639
8:00AM | 7:00PM



Subject to certain limitations and exclusions. Only spare parts.
Sujeto a limitaciones y exclusiones. Solo piezas de repuesto.



VERTICAL SYSTEM
SISTEMA VERTICAL