

**FD/HD**

---



DESPIECE / REPUESTOS  
EXPLODED VIEW / SPARE PARTS  
EXPLOSIONSZEICHNUNG / ERSATZTEILE  
VUE ÉCLATÉE / PIÈCES DÉTACHÉES  
ESPLOSO / RICAMBI



# CABINET



FD/HD

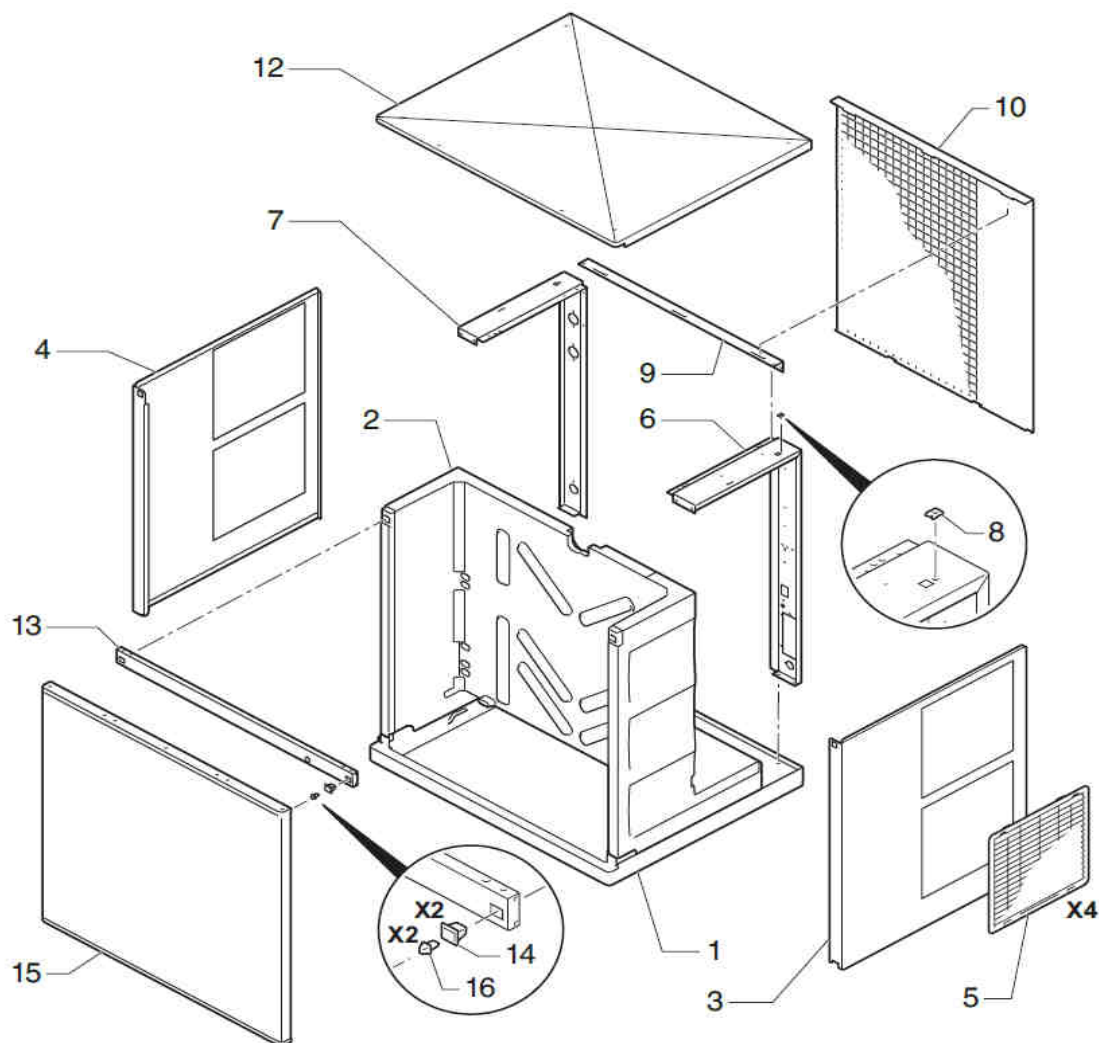

	DESCRIPTION	MODEL	
		FD/HD 215	FD/HD 415
1	BASE PLAT	6074	6074
2	INSULATED BODY	6342	6343
3	RIGHT SIDE PANEL	6327	6329
4	LEFT SIDE PANEL	6328	6330
5	SIDE GUARD	6084	6084
6	RIGHT BRACKET	6319	6320
7	LEFT BRACKET	6325	6324
8	FAST NUT	311	311
9	UPPER REAR BRACKET	6321	6321
10	REAR PANEL	6315	6316
11	TOP PANEL	6073	6073
12	FRONT BRACKET	6331	6331
13	FEMALE PANEL CLIP	6180	6180
14	FRONT PANEL	6269	6270
15	MALE PANEL CLIP	6181	6181

# MANUFACTURING CONTAINER



FD/HD

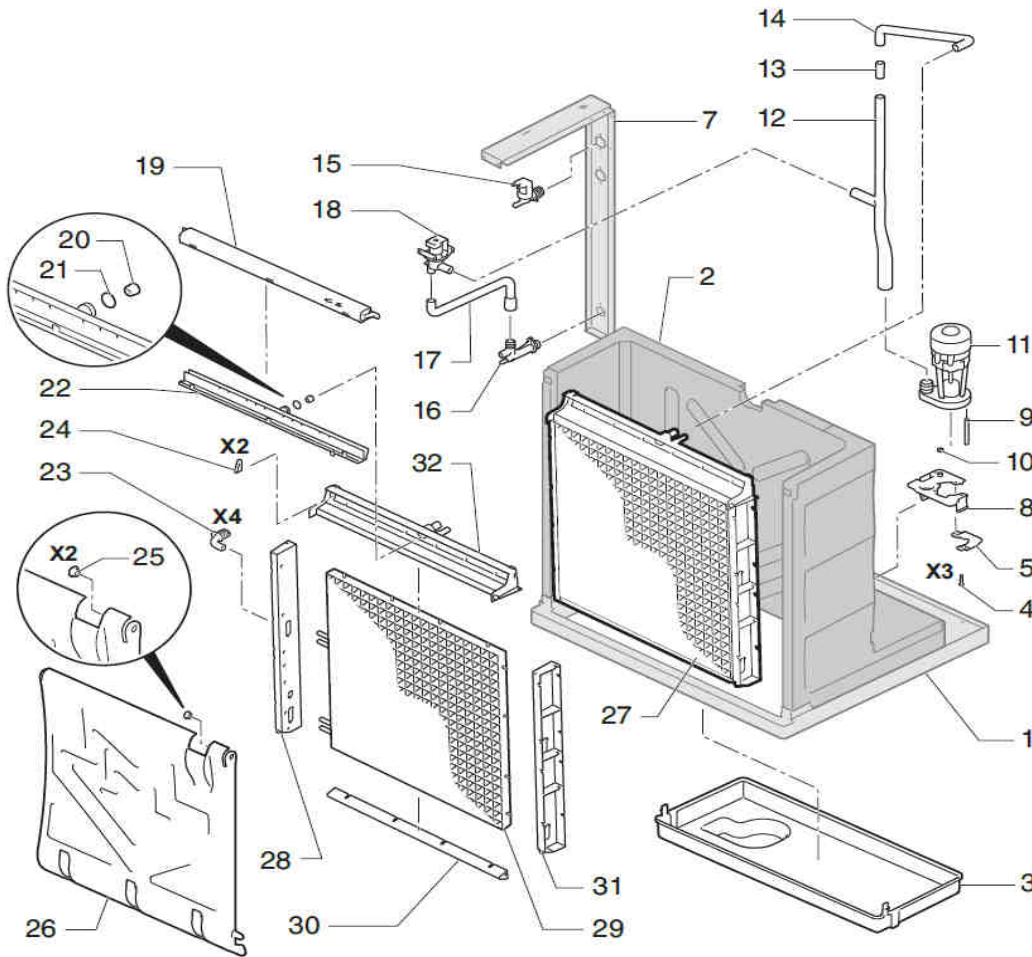

	DESCRIPTION	MODEL	
		FD/HD 215	FD/HD 415
1	BASE PLATE	6074	6074
2	INSUALTED BODY	6342	6343
3	WATER BIN	6078	6078
4	INOX SCREW M5x20	7931	7931
5	PUMP BRACKET TERMINATION	6106	6106
7	LEFT BRIDGE	6325	6324
8	PUMP BRACKET	6079	6079
9	PUMP EARTHING CABLE	6454	6454
10	COMPRESSING RING	504	504
11	WATER PUMP	6509	6509
12	BOTTOM TUBE	6130	6130
13	CONNECTION TUBE	6526	6526
14	TOP TUBE	6129	6129
	WATER VALVE 220V/50-60HZ	7688	7688
15	WATER VALVE 220V/50-60HZ water cooled	329	7688
	WATER VALVE 220V/50-60HZ UL	-	8963
16	DRAIN MANIFOLD	6206	6206
17	DRAIN TUBE	6131	6131
18	WATER DRAIN VALVE 220V/50-60HZ	6183	6183
19	DISTRIBUTOR COVER	30039	30039
	GREY DISTRIBUTOR COVER	30039G	30039G
20	FLOW REDUCER 7MM	6414	6414
21	FLOW REDUCER 9MM	6485	6485
21	O-RING	4496	4496
22	DISTRIBUTOR	30039	30039
	GREY DISTRIBUTOR	30039G	30039G
23	TUBE PROTECTION	6132	6132
24	DISTRIBUTOR GASKET	6456	6456
25	BEARING	1001	1001
26	CURTAIN	6081	6080
27	COMPLETE EVAPORATOR DICE 1"	6337	6339
	COMPLETE EVAPORATOR DICEO 1/2"	6338	6340
28	EVAPORATOR LEFT PANEL	2982	2978
29	NICKEL-PLATED EVAPORATOR DICE 1"	5747	5753
	NICKEL-PLATED EVAPORATOR DICE 1/2"	5744	5750
30	EVAPORATOR BOTTOM PANEL	6086	6086
31	EVAPORATOR RIGHT PANEL	2981	2977
32	EVAPORATOR TOP PANEL	6085	6085

# ELECTRIC BOX

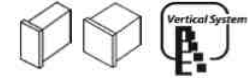

FD/HD

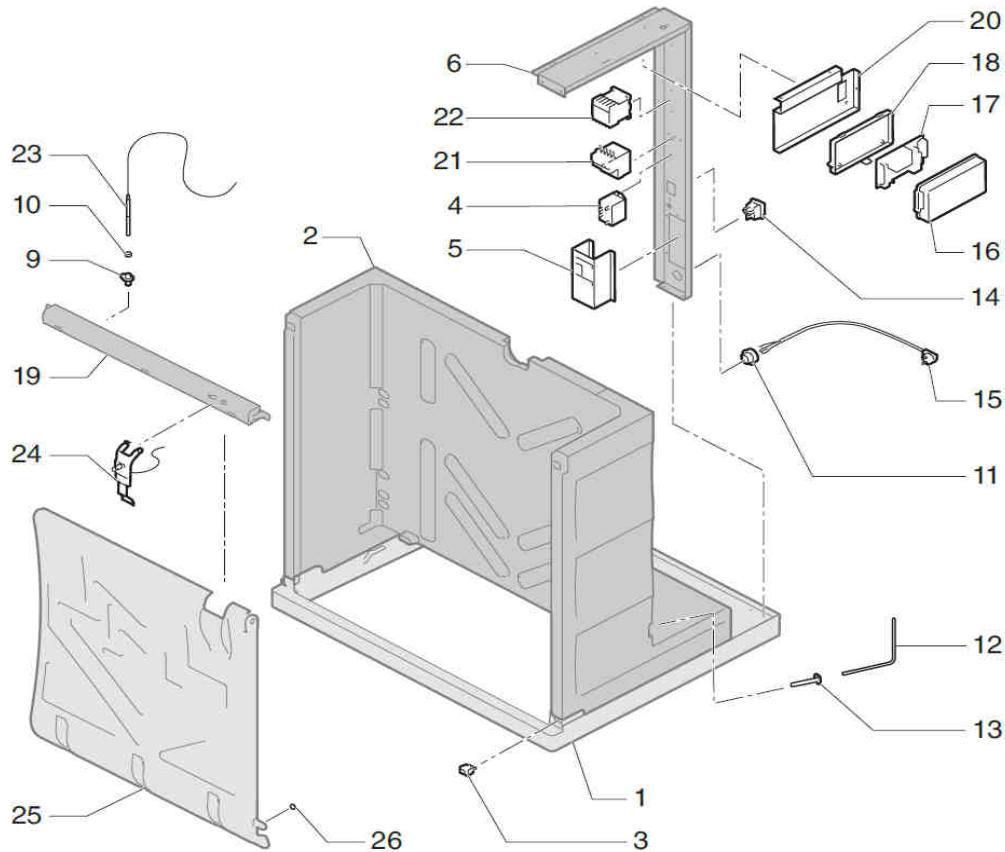

	DESCRIPTION	MODEL	
		FD/HD 215	FD/HD 415
1	BASE PLATE	6074	6074
2	INSULATED BODY	6342	6343
3	SWITCH (ICE-OFF-WASH)	6161	6161
4	STARTER RELAY 220V	2968	2968
5	ELECTRICAL BOX (3 PHASE)	-	6322
6	RIGHT BRIDGE	6319	6320
9	LEVEL PROBE BRACKET	8670	8670
10	COMPRESSING RING	504	504
11	CABLE RESTRAINT	4907	4907
12	CURTAIN PROBE	6521	6521
13	CURTAIN PROBE BLOCK	8671	8671
14	ON/OFF SIWTCH	2287	2287
15	ELECTRIC SUPPLY WIRE 220V/50-60HZ	408	2124
15	ELECTRIC SUPPLY WIRE 220V/60HZ	-	3675
16	ELECTRIC BOX COVER	30861	30861
17	ELECTRONIC BOARD 220V/50-60HZ	6252A	6252A
17	ELECTRONIC BOARD BEFORE S/N 17736480	30922	30922
18	ELECTRIC BOX	2181	2181
19	DISTRIBUTOR COVER	30039	30039
20	ELECTRIC BOX BRACKET	6138	6138
21	THERMAL RELAY (3 PHASE)	-	3022
22	CONTACTOR (3 PHASE)	-	536
23	WATER LEVEL PROBE	30982	30982
24	THICKNESS ICE PROBE	6334	6334
25	CURTAIN	6081	6080
26	MAGNET	6179	6179

# AIR CONDENSER

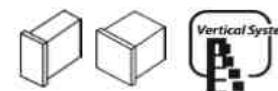

FD/HD

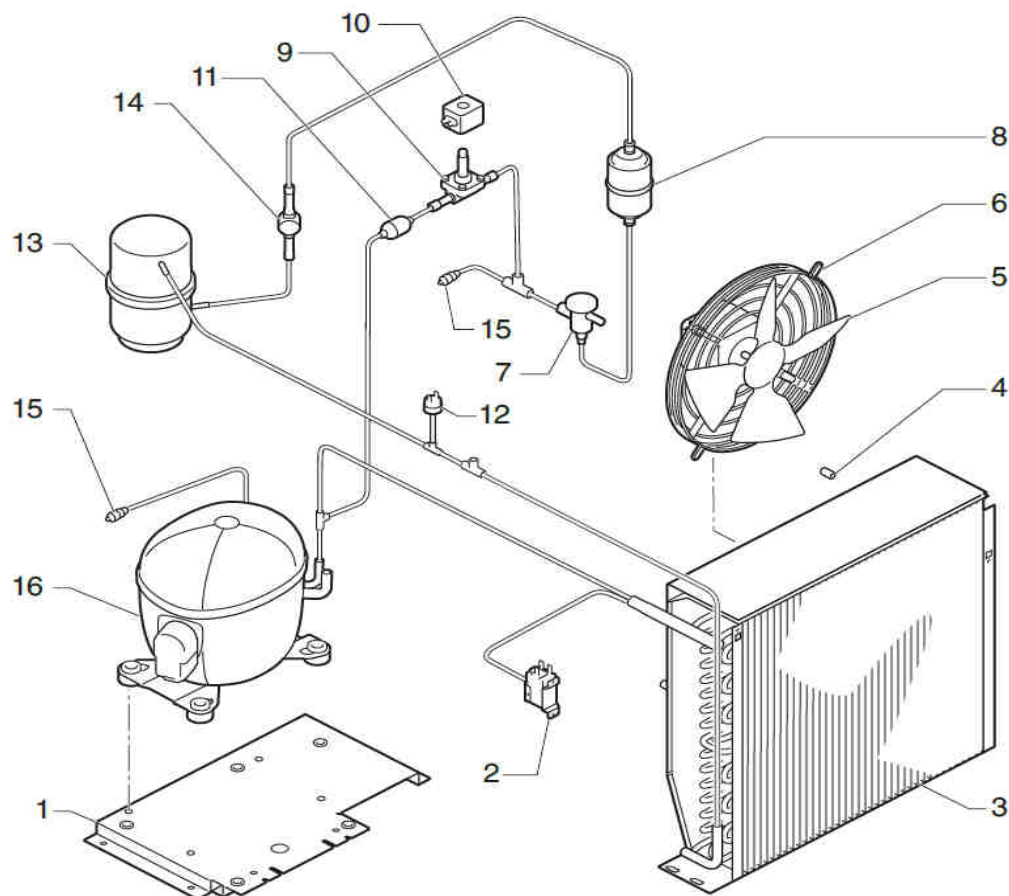

	DESCRIPTION	MODEL		
		FD/HD 215	FD/HD 415	
1	BASE PLATE	6326	6326	
2	CONDENSATION PRESSURE SWITCH	2507	2507	
3	AIR CONDENSER	6156	6157	
4	FAN BLADE SUPPORT	6500	6501	
5	FAN BLADE 220/380V 50HZ	4994	6557	
	FAN BLADE 203-230V/3ph/60HZ	-	6398	
6	FAN BLADE 220V/50-60HZ	3077	2446	
	FAN BLADE 203-230V/3ph/60HZ	-	4894	
7	EXPANSION VALVE	1035	1035	
8	DRIER FILTER	2560	2560	
9	HOT GAS VALVE	6396	843	
10	COIL 220V/50-60HZ	5173	5173	
12	HIGH PRESSURE SWITCH	334	334	
13	PRESSURE TANK (UNLISTED MODELS)	6241	6241	
14	SIGHT (UNLISTED MODELS)	336	336	
15	LOAD VALVE	335	335	
	COMPRESSOR			
		220V/50HZ	6008	8450
16		220V/60HZ	31099	8304
		220V/60HZ/3PH	-	6569
		380V/50HZ/3PH	-	3214

# WATER CONDENSER

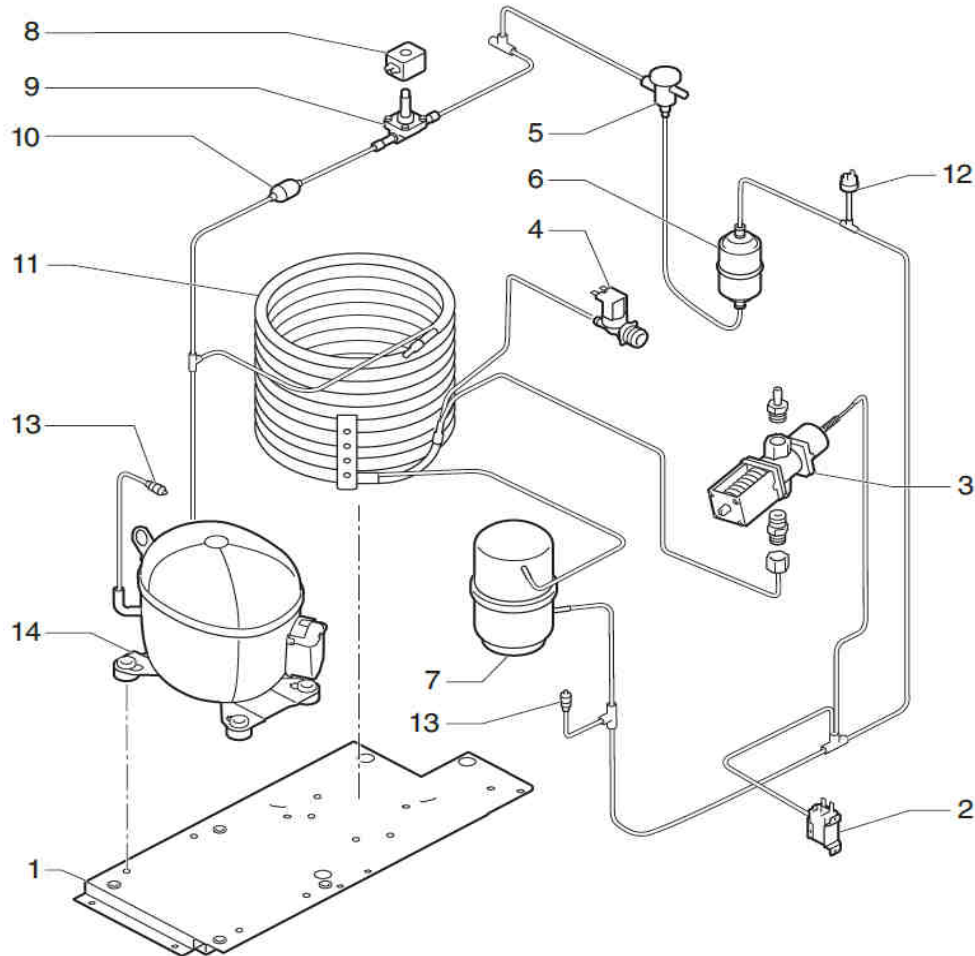

	DESCRIPTION	MODEL	
		FD/HD 215	FD/HD 415
1	PLATE BASE	6326	6326
2	CONDENSATION PRESSURE SWITCH	2507	-
3	PRESSURE SWITCH VALVE	-	425
4	WATER VALVE 220V/50-60HZ	6183	6183
5	EXPANSION VALVE	1035	1035
6	DRIER FILTER	2560	2560
7	PRESSURE TANK	6241	6241
8	HOT GAS VALVE	6396	843
9	COIL 220V/50-60HZ	5173	5173
11	WATER CONDENSER	5246	3268
12	HIGH PRESSURE SWITCH	334	334
13	LOAD VALVE	335	335
14	COMPRESSOR		
	220V/50HZ	6008	8450
	220V/60HZ	31099	8304
	220V/60HZ/3PH	-	6569
	380V/50HZ/3PH	-	3214