

**FD/HD 315 SLIM**

---



**EUROICE**

DESPIECE / REPUESTOS  
EXPLODED VIEW / SPARE PARTS  
EXPLOSIONSZEICHNUNG / ERSATZTEILE  
VUE ÉCLATÉÉ / PIÈCES DÉTACHÉES  
ESPLOSO / RICAMBI

---

 **EUROICE**

# CABINET

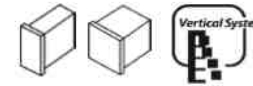

FD/HD 315 SLIM

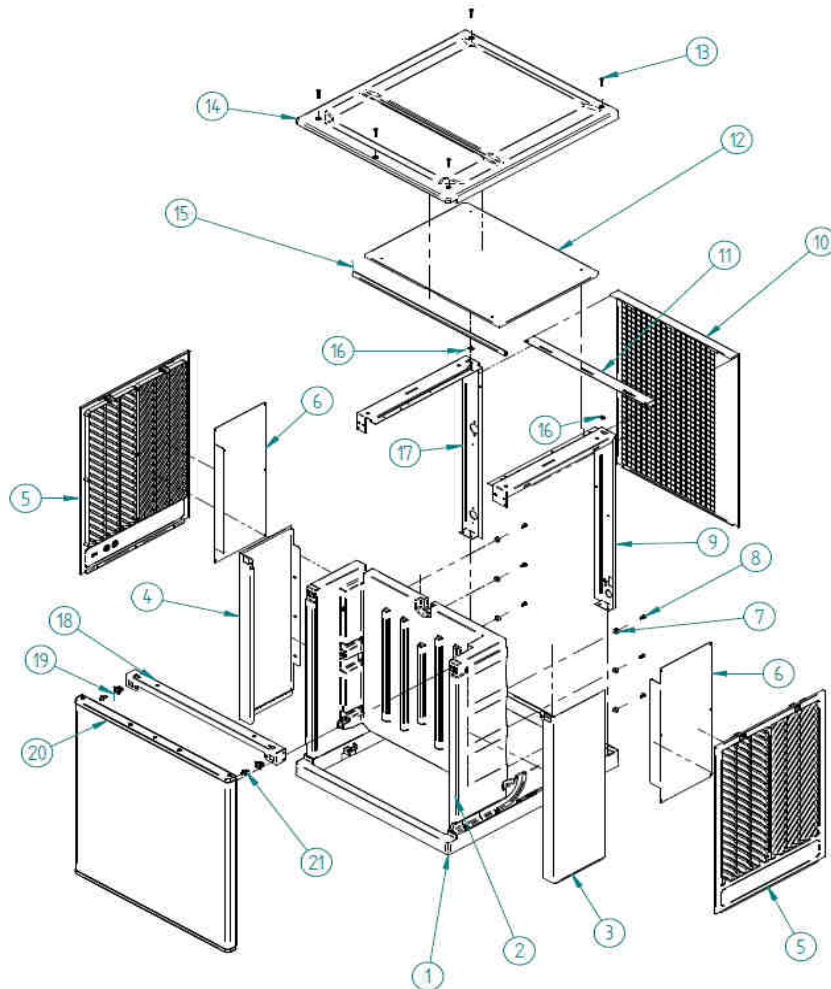

	DESCRIPTION	MODEL
		FD/HD 215
1	BASE PLAT	30412
2	INSULATED BODY	30428
3	RIGHT SIDE PANEL	30747
4	LEFT SIDE PANEL	30748
5	SIDE GRILLE	30424
6	SIDE GRILLE COVER	30908
7	LEGS	2171
8	SCREW 4.8X13	275
9	RIGHT SUPPORT	30742
10	REAR COVER	30746
11	REAR BRACE	30743
12	METALLIC FIREWALL COVER	30909
13	BLACK SCREW 3.9X25	30910
14	COVER	30423
15	COVER PIECE	30753
16	NUT	311
17	LEFT SUPPORT	30744
18	FRONT BRACE	30745
19	CLIP	6180
20	FRONT DOOR	30749
21	MALE CLIP	6181

# MANUFACTURING CONTAINER



FD/HD 315 SLIM

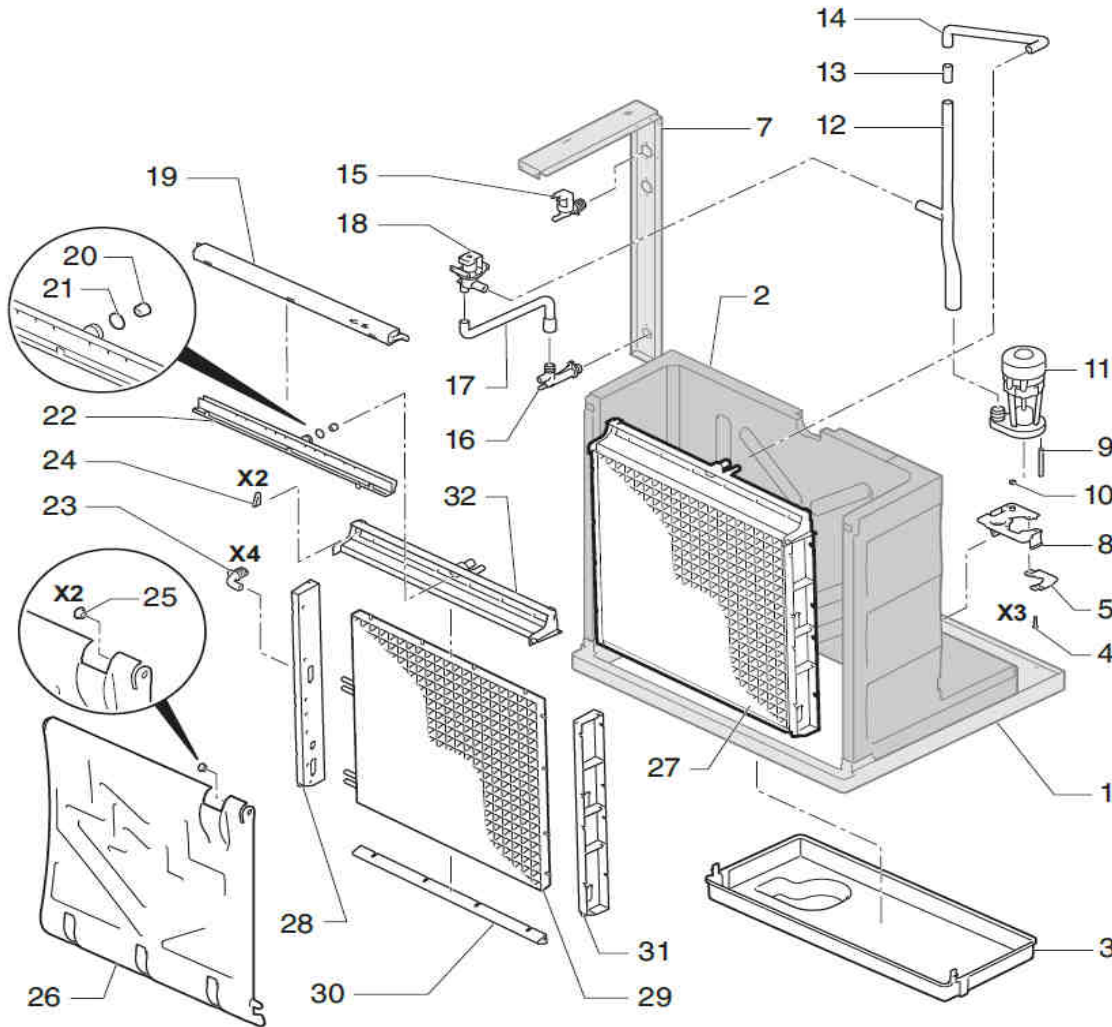

	DESCRIPTION	MODEL FD/HD 315
1	WATER TRAY	30413
2	BENCH	30412
3	SCREW 5X20	7931
4	PUMP SUPPORT	6079
5	PUMP SUPPORT TERMINATION	6106
6	PUMP EARTHING WIRE	6454
7	PUMP 220V/50-60HZ	6509
	PUMP 115V/60HZ	6508
8	BOTTOM TUBE	30469
9	CAP	30683
10	BODY	30428
11	FLOW REDUCER 7mm	30784
12	TOP TUBE	30684
13	LEFT SUPPORT	30744
14	WATER VALVE 220V/50-60HZ	7688
	WATER VALVE 115V/60HZ	7687
15	DRAIN VALVE 115V/60HZ	6182
	DRAIN VALVE 220V/50-60HZ	6183
16	DRAIN TUBE	30468
17	DRAIN TUBE CONNECTOR	30850
18	DISTRIBUTOR CAP	30682
19	WATER DISTRIBUTOR COVER	30427
20	WATER DISTRIBUTOR	30422
21	DOOR BEARING	1001
22	CURTAIN	30420
23	EVAPORATOR LEFT PANEL	30419
24	EVAPORATOR 1/2"	30690
	EVAPORATOR 1"	30906A
25	EVAPORATOR BOTTOM PANEL CLIP	30415
26	EVAPORATOR BOTTOM PANEL	30414
27	EVAPORATOR RIGHT PANEL	30418
28	EVAPORATOR TOP PANEL CLIP	30417
29	EVAPORATOR TOP PANEL	30416
30	COMPLETE EVAPORATOR 1/2"	
	COMPLETE EVAPORATOR 1"	

# ELECTRIC BOX



FD/HD 315 SLIM

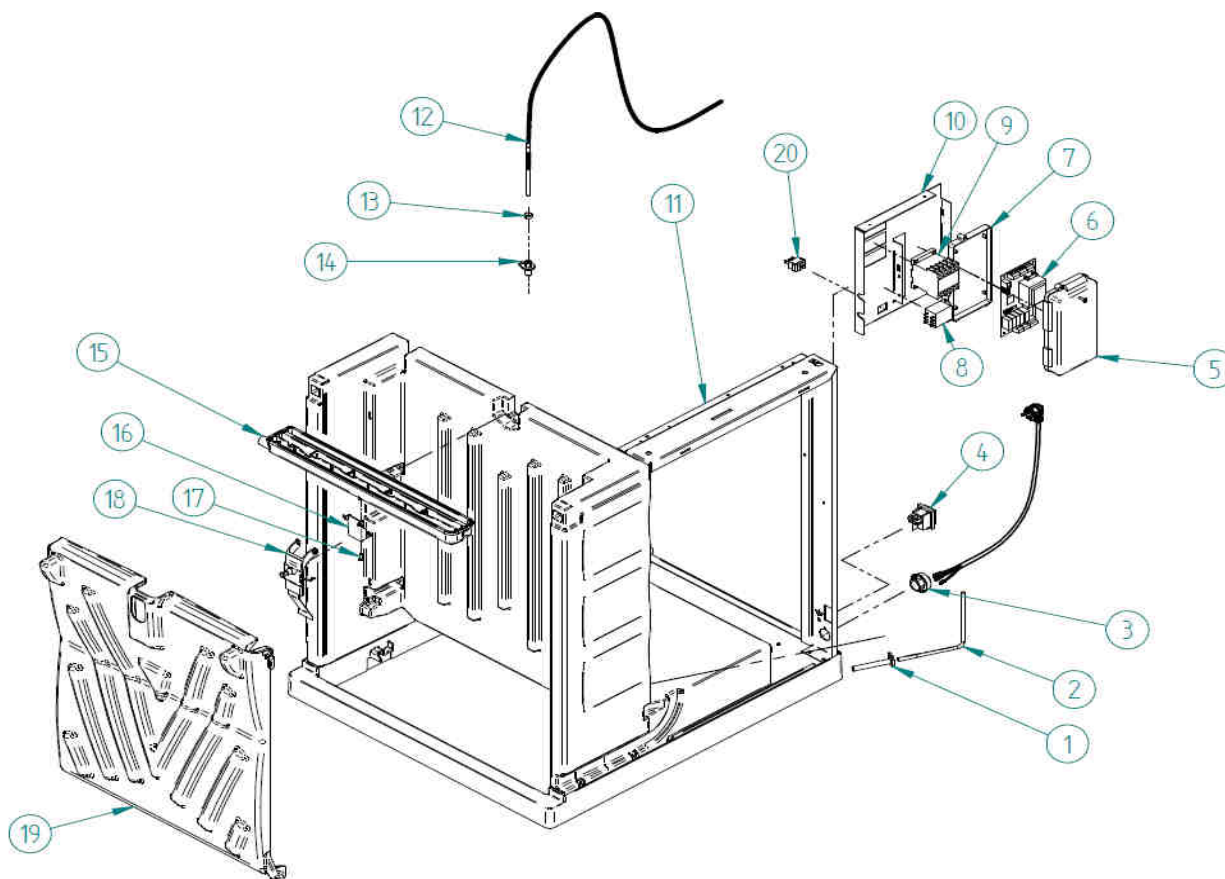

DESCRIPTION		MODEL
		FD/HD 215
1	CURTAIN SENSOR END	8671
2	CURTAIN SENSOR	6178
3	RETAINER	4907
4	MAIN SWITCH	2287
5	ELECTRIC BOX COVER	30861
6	ELECTRONIC BOARD 220V/50-60HZ	6252A
6	ELECTRONIC BOARD 115V/60HZ	6253A
7	ELECTRONIC BOX	2181
8	RELAY 220V/50-60HZ	1483
8	RELAY 115V/60HZ	2987
9	CONTACTOR 220V/50-60HZ	1002
9	CONTACTOR 115V/60HZ	30027A
10	BOX SUPPORT	30741
11	RIGHT SUPPORT	30742
12	WATER LEVEL PROBE	6335
13	WASHER	504
14	WATER LEVEL SUPPORT	8670
15	WATER DISTRIBUTOR	30422
16	THICKNESS SENSOR SUPPORT	30421
17	SCREW 3.X12.7	243
18	THICKNESS SENSOR	6334
19	CURTAIN	30420
20	3 POSITION SWITCH	6161

# AIR CONDENSER



**FD/HD 315 SLIM**

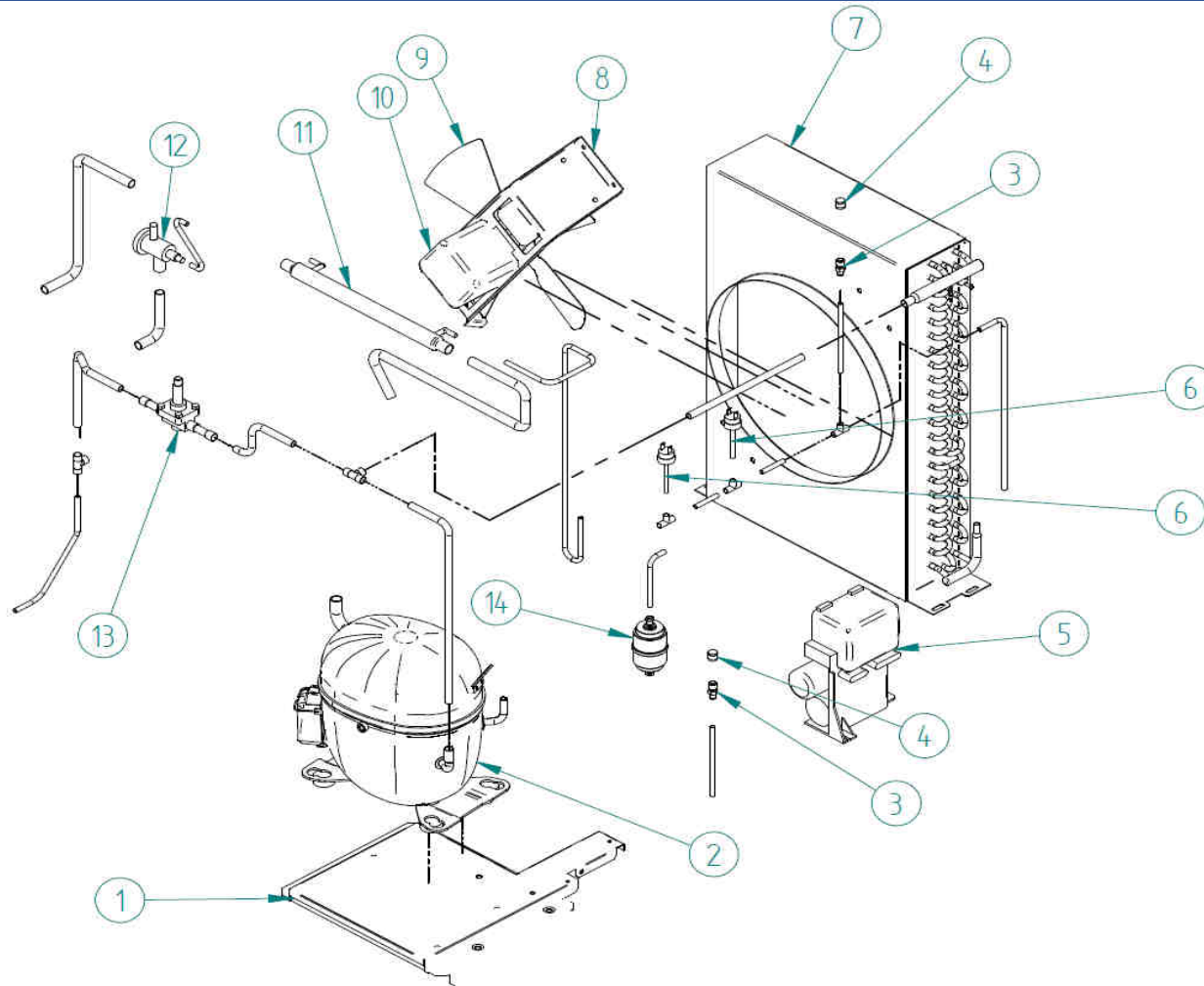

	DESCRIPTION	MODEL FD/HD 315
1	BENCH	30868
	COMPRESSOR 115V/60HZ	30662
2	COMPRESSOR 220V/50HZ	31183
	COMPRESSOR 220V/60HZ	31340
3	CHARGING VALVE	335
6	HIGH PRESSURE SWITCH	334
7	CONDENSER	30429
8	FAN SUPPORT	6501
9	FAN BLADE	6398
10	FAN MOTOR 115V/60HZ	8096
	FAN MOTOR 220V/50-60HZ	2446
11	HEAT EXCHANGER	8575
12	EXPANSION VALVE #6	1035
13	HOT GAS VALVE	31014
14	DRIER	2560