

# GR N 310

230 V / 50 Hz

## MODULAR NUGGET ICE MACHINE







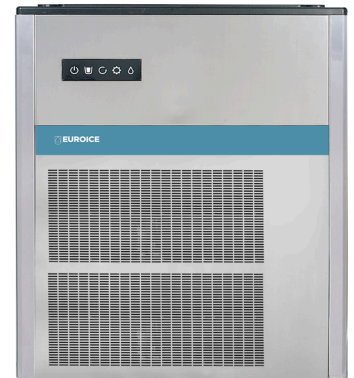





### FEATURES CARACTERÍSTICAS

- ▶ **PRODUCES NUGGET ICE**  
PRODUCE HIELO NUGGET
- ▶ **HIGH EVAPORATOR EFFICIENCY: LOWER ENERGY CONSUMPTION AND HIGHER ICE PRODUCTION**  
EVAPORADOR DE ALTA EFICIENCIA: MENOR GASTO ENERGÉTICO, MAYOR PRODUCCIÓN DE HIELO
- ▶ **AUTODIAGNOSIS LED LIGHTS SIGNALING OPERATION STATUS & ALERTS**  
AUTODIAGNOSIS CON SEÑALIZACIÓN DE LEDS SOBRE EL FUNCIONAMIENTO Y ALERTAS
- ▶ **ELECTRONIC CONTROL. ON/OFF LIGHTED SWITCH IN FRONT PANEL**  
ELECTRONIC CONTROL. BOTÓN ENCENDIDO/APAGADO LUMINOSO EN PANEL FRONTAL
- ▶ **STAINLESS STEEL AUGER WITH RESILIENT COATING TO MAXIMIZE LIFESPAN**  
HUSILLO DE ACERO INOXIDABLE CON POSTERIOR TRATAMIENTO SUPERFICIAL PARA AUMENTAR SU VIDA ÚTIL
- ▶ **POWERFUL MOTOR GEAR**  
POTENTE MOTOR REDUCTOR
- ▶ **AISI 304 STAINLESS STEEL BODY**  
CARROCERÍA EN ACERO INOXIDABLE AISI 304
- ▶ **OPTICAL PINPOINT CONTROL SYSTEM TO SET ICE STOCK LEVEL. ICE DROPS OUT THROUGH THE OPENING ON THE BOTTOM OF THE UNIT**  
REGULACIÓN DEL STOCK DE HIELO MEDIANTE UN SISTEMA DE CONTROL ÓPTICO DE PRECISIÓN. EL HIELO SALE POR UNA ABERTURA EN LA PARTE INFERIOR DE LA UNIDAD
- ▶ **TROPICALIZED MACHINES (T CLASS)**  
MÁQUINAS TROPICALIZADAS (CLASE T)
- ▶ **NATURAL GAS R290 WITH VERY LOW GLOBAL WARMING POTENTIAL WHICH ALSO REDUCES THE ENERGY CONSUMPTION**  
GAS NATURAL R290 CON MUY BAJO ÍNDICE GWP EL CUAL TAMBIÉN REDUCE EL CONSUMO ENERGÉTICO



**THE INSTALLATION OF AN ANTI-SCALE FILTER AND PERIODIC CLEANING ARE ADVISED IN AREAS WITH MEDIUM OR HIGH LIMESCALE CONTENT (HARD WATER)**  
SE ACONSEJA LA INSTALACIÓN DE UN FILTRO ANTICAL Y LIMPIEZA PERIÓDICA EN CASO DE AGUAS CON CONTENIDO EN CAL MEDIO O ALTO (AGUAS DURAS)

	 24 H	 10°C	 10°C	 21°C	 15°C	 (mm)	 (mm)	
GR N 310 A		378	364	Width 559 Depth 622 Height 712	Width 636 Depth 695 Height 835	<b>NUGGET ICE</b> 90% DRY (+/-2%)		
GR N 310 W		-	-					

### ACCESSORIES ACCESORIOS

#### INCLUDED



**WATER INLET FILTER GASKET**  
JUNTA DE FILTRO DE ENTRADA DE AGUA



**WATER INLET HOSE**  
MANGUERA DE ENTRADA DE AGUA



**WATER OUTLET HOSE**  
MANGUERA DE DESAGÜE

#### OPTIONAL (NOT INCLUDED)



**LARGE SCOOP**  
PALA GRANDE



**ICE DELIVERY CHUTE**  
TUBO CAÍDA DE HIELO



**DISPERSION CONE**  
CONO DE DISPERSIÓN



**ANTI-LIMESCALE FILTER**  
FILTRO ANTICAL



**PARTICLE FILTER**  
FILTRO ANTIPARTÍCULAS



**EXTERNAL STOP FULL BIN PHOTO CELL**  
SENSOR DE PARO EXTERNO POR LLENADO

### RECOMMENDED BINS DEPÓSITOS RECOMENDADOS



B175 + GR N 310



B210 + GR N 310



B340 + GR N 310



B400 + GR N 310



B500 + GR N 310



BCS150 + GR N 310



BCS300 + GR N 310



BCD400 + GR N 310



BCD600 + GR N 310



BCD800 + GR N 310

GR N 310

RIGHT SIDE VIEW  
VISTA LATERAL DERECHO

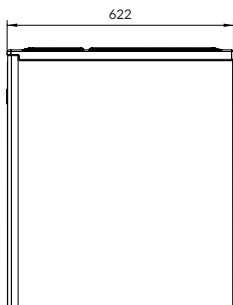

FRONTAL VIEW  
VISTA FRONTAL

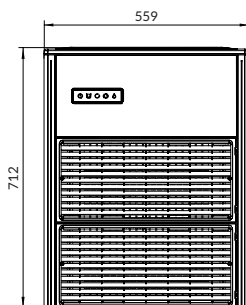

REAR VIEW  
VISTA TRASERA

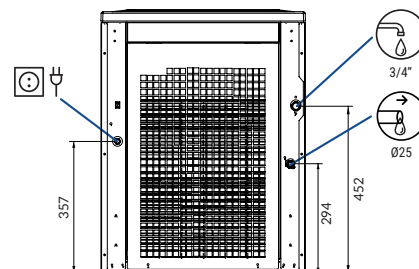

CENTRAL CROSS SECTION VIEW OF THE BASE  
VISTA DE LA BASE DESDE SECCIÓN CENTRAL

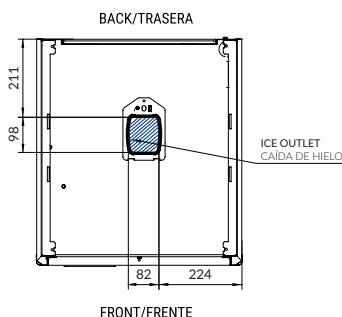

\*All measurements in mm.  
\*Todas las cotas en mm.

OPERATING CONDITIONS CONDICIONES DE OPERACIÓN

PRODUCTION 50Hz PRODUCCIÓN 50 Hz

±10% V

10°C/43°C

5°C/38°C

1 bar/6 bar



V	Hz	ph
230	50	1N

GR N 310 AIR COOLED

°C / °F	10° / 50°	15° / 60°	21° / 70°	30° / 86°
10° / 50°	378	370	360	350
21° / 68°	368	335	347	320
32° / 90°	325	310	304	298
43° / 109°	285	270	261	255

GR N 310 WATER COOLED

°C / °F	10° / 50°	15° / 60°	21° / 70°	30° / 86°
10° / 50°	-	-	-	-
21° / 68°	-	-	-	-
32° / 90°	-	-	-	-
43° / 109°	-	-	-	-

MODELS  
MODELOS



Temp. Ev.  
(°C)

ASHRAE CONDITIONS  
CONDICIONES ASHRAE  
(W) (BTU/h)

(W) 43°C

(n.) (mm<sup>2</sup>)

FUSE

100 Kg  
(Kwh)

(l/h)

HEAT REJECTED  
(W) (BTU/h)

(Kg)

(Kg)

(m<sup>3</sup>)

GR N 310 A



-15°

3.240 11.055

1.316

3 1,5

16

9,7

12,7

2.544 8.680

84

93

0,37

GR N 310 W



-

-

-

-

-

-

-

-

-

-

-



EUROICE  
P.I. La Reva, Av. Gremis, 1  
46190 Ribarroja - Valencia - España  
Phone: +34 96 166 76 36 | Fax: +34 961 668 944  
www.euroice.it/ | info@euroice.it



SERVICE  
SERVICIO ASISTENCIA TÉCNICA  
service@euroice.it  
+34 961 667 639  
8:00AM | 7:00PM



Subject to certain limitations and exclusions. Only spare parts.  
Sujeto a limitaciones y exclusiones. Solo piezas de repuesto



9001  
14001

