



SC 600 REMOTE





THREE PHASE
400 V / 50 Hz

MODULAR FLAKE ICE MACHINE WITH REMOTE UNIT

FEATURES CARACTERÍSTICAS

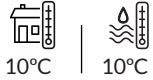
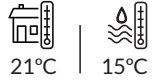
- ▶ PRODUCES COLD AND DRY FLAT FLAKES. FLAKE THICKNESS MAY BE ADJUSTED BETWEEN 1.5 mm AND 3 mm
PRODUCE ESCAMAS PLANAS MUY FRÍAS Y SECAS. EL ESPESOR PUEDE REGULARSE ENTRE 1.5 Y 3 mm
- ▶ BASED ON A STATIC CYLINDER WHICH IS FREE FROM SWIVEL JOINTS (HELICAL REAMER) COUPLED WITH A MILLING TOOL THAT DETACHES THE ICE WITHOUT ANY STRAINED OR FORCED MOVEMENTS
FUNCIONAMIENTO BASADO EN UN CILINDRO ESTÁTICO SIN JUNTAS GIRATORIAS (HELICAL REAMER) Y CON UNA FRESA QUE DESPEGA EL HIELO SIN TENSIONES NI ESFUERZOS
- ▶ THE MOST EFFICIENT EVAPORATOR OF THE MARKET, LESS ENERGY CONSUMPTION AND HIGHER ICE PRODUCTION
EL EVAPORADOR MAS EFICIENTE DEL MERCADO, MENOR GASTO ENERGÉTICO, MAYOR PRODUCCIÓN DE HIELO
- ▶ ELECTRONIC STOP SYSTEM / ELECTRICAL CONTROL PANEL / DRIVE DIRECT GEAR MOTOR / MAGNETIC DRIVE PUMP / LOW WATER SAFETY DEVICE
SISTEMA DE PARO ELECTRÓNICO / CUADRO ELÉCTRICO DE REGULACIÓN / MOTORREDUCTOR DE ATAQUE DIRECTO / BOMBA DE ARRASTRE MAGNÉTICO / SEGURIDAD ANTE FALTA DE AGUA
- ▶ STAINLESS STEEL SOLEPLATE
BANCADA DE ACERO INOXIDABLE
- ▶ CONTROLLERS TO DETECT: LOW WATER LEVEL, TEMPERATURE RISE DUE TO MOTOR OVERLOAD OR FULL VAT
CONTROLES PARA DETECTAR: FALTA DE NIVEL DE AGUA, AUMENTO DE TEMPERATURA POR SOBRESFUERZO EN EL MOTORREDUCTOR O POR LLENADO DE ALMACÉN

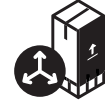

	 24 H (Kg)	 10°C 10°C (Kg)	 21°C 15°C (Kg)	 (mm)	 (mm)	 FLAKE ICE
SC 600 SPLIT	 675	600	Width 1.250 Depth 750 Height 835	Width 1.350 Depth 860 Height 970		
RCU 600	-	-	Width 1.108 Depth 574 Height 690	Width 1.200 Depth 600 Height 800		

ACCESSORIES ACCESORIOS

INCLUDED



WATER INLET FILTER GASKET
JUNTA DE FILTRO DE ENTRADA DE AGUA



WATER INLET HOSE
MANGUERA DE ENTRADA DE AGUA



WATER OUTLET HOSE
MANGUERA DE DESAGÜE

NOT INCLUDED (OPTIONAL)



ICE DROP CHUTE
TUBO DE CAÍDA DE HIELO



SALT DOSING PUMP WITH TANK
BOMBA DOSIFICADORA DE SAL CON DEPÓSITO



REMOTE SWITCH FILTER
INTERRUPTOR REMOTO



REMOTE SWITCH & WEEKLY PROGRAMMER
INTERRUPTOR REMOTO CON PROGRAMADOR SEMANAL



EXTERNAL STOP FULL BIN PHOTO CELL
SENSOR DE PARO EXTERNO POR LLENADO

RECOMMENDED BINS SILOS RECOMENDADOS



B500 + SC 600 SPLIT



BCD400 + SC 600 SPLIT



BCD600 + SC 600 SPLIT



BCD800 + SC 600 SPLIT

SC 600 SPLIT

RIGHT SIDE VIEW
VISTA LATERAL DERECHA

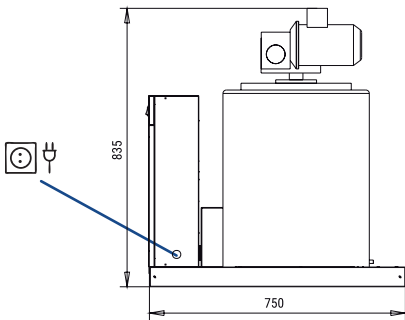

FRONTAL VIEW
VISTA FRONTAL

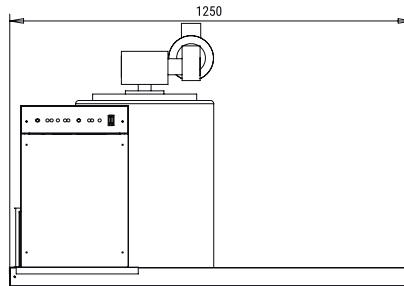

LEFT SIDE VIEW
VISTA LATERAL IZQUIERDA

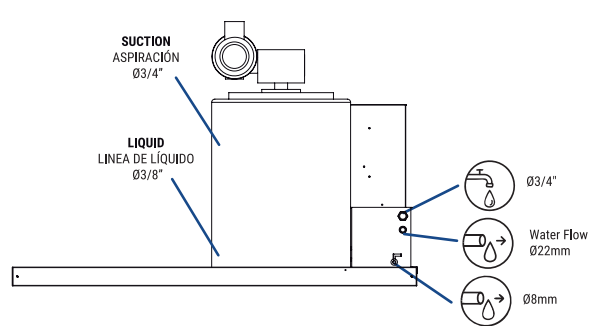

RCU 600

CENTRAL CROSS SECTION VIEW OF THE BASE
VISTA DE LA BASE DESDE SECCIÓN CENTRAL

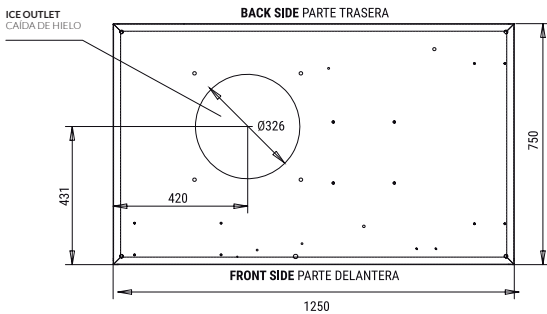

RIGHT SIDE VIEW
VISTA LATERAL DERECHA

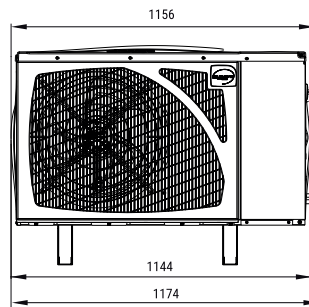

RIGHT SIDE VIEW
VISTA LATERAL DERECHA

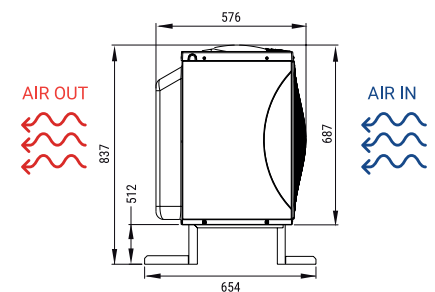

* All measurements in mm.
* Todas las cotas en mm.

OPERATING CONDITIONS CONDICIONES DE OPERACIÓN

PRODUCTION 50Hz PRODUCCIÓN 50 Hz

- ±10% V
- 5°C/43°C
- 5°C/35°C
- 1 bar/6 bar

V	Hz	ph
400	50	3N

SC 600 REMOTE

°C	10°	15°	21°	30°
°F	50°	60°	70°	86°
10°	675	630	525	465
50°	660	600	503	435
21°	615	540	450	390
68°	503	435	345	300
32°				
90°				
43°				
109°				

SC 600 REMOTE

°C	10°	15°	21°	30°
°F	50°	60°	70°	86°
10°	628	586	488	432
50°	614	558	467	405
21°	572	502	419	363
68°	467	405	321	279
32°				
90°				
43°				
109°				

MODELS
MODELOS

	Temp.EV. (°C)	ASHRAE CONDITIONS CONDICIONES ASHRAE (W) (BTU/h)	(W) 43°C	(n.) (mm ²)	FUSE	100 Kg (Kw/h)	(l/h)	HEAT REJECTED (W) (BTU/h)	(Kg)	(Kg)	(m ³)
SCALA 600 S	-22	3.300 11.260	190	3 1,5	16	6,1*	25	- -	120	150	1,12
RCU 600	-	- -	2.160	5 2,5	16	-	-	3.960 13.512	86	95	0,57



EUROICE
P.I. La Reva, Av. Gremis, 1
46190 Ribarroja - Valencia - España
Phone: +34 96 166 76 36 | Fax: +34 961 668 944
www.euroice.it/ | info@euroice.it



SERVICE
SERVICIO ASISTENCIA TÉCNICA
service@euroice.it
+34 961 667 639
8:00AM | 7:00PM



Subject to certain limitations and exclusions. Only spare parts. Sujepto a limitaciones y exclusiones. Solo piezas de repuesto.



9000
9001
14000

